

DRAFT UGANDA STANDARD

First Edition
2019-mm-dd

Air freshener aerosols — Specification

PUBLIC REVIEW DRAFT

Reference number
DUS DEAS 956: 2019

Compliance with this standard does not, of itself confer immunity from legal obligations

A Uganda Standard does not purport to include all necessary provisions of a contract. Users are responsible for its correct application

© UNBS 2019

All rights reserved. Unless otherwise specified, no part of this publication may be reproduced or utilised in any form or by any means, electronic or mechanical, including photocopying and microfilm, without prior written permission from UNBS.

Requests for permission to reproduce this document should be addressed to

The Executive Director
Uganda National Bureau of Standards
P.O. Box 6329
Kampala
Uganda
Tel: +256 417 333 250/1/2
Fax: +256 414 286 123
E-mail: info@unbs.go.ug
Web: www.unbs.go.ug

National foreword

Uganda National Bureau of Standards (UNBS) is a parastatal under the Ministry of Trade, Industry and Cooperatives established under Cap 327, of the Laws of Uganda, as amended. UNBS is mandated to coordinate the elaboration of standards and is

- (a) a member of International Organisation for Standardisation (ISO) and
- (b) a contact point for the WHO/FAO Codex Alimentarius Commission on Food Standards, and
- (c) the National Enquiry Point on TBT Agreement of the World Trade Organisation (WTO).

The work of preparing Uganda Standards is carried out through Technical Committees. A Technical Committee is established to deliberate on standards in a given field or area and consists of representatives of consumers, traders, academicians, manufacturers, government and other stakeholders.

Draft Uganda Standards adopted by the Technical Committee are widely circulated to stakeholders and the general public for comments. The committee reviews the comments before recommending the draft standards for approval and declaration as Uganda Standards by the National Standards Council.

This Draft Uganda Standard, DUS DEAS 956: 2019, *Air freshener aerosols — Specification*, is identical with and has been reproduced from an International Standard, DEAS 956: 2019, *Air freshener aerosols — Specification*, and is being proposed for adoption as a Uganda Standard.

The committee responsible for this document is Technical Committee UNBS/TC 5, *Chemicals and environment*, Subcommittee SC 1, *Industrial and public health chemicals*.

Wherever the words, "East African Standard " appear, they should be replaced by "Uganda Standard."



DEAS 956: 2019

ICS 71.100.70

DRAFT EAST AFRICAN STANDARD

Air freshener aerosols — Specification

EAST AFRICAN COMMUNITY

Copyright notice

This EAC document is copyright-protected by EAC. While the reproduction of this document by participants in the EAC standards development process is permitted without prior permission from EAC, neither this document nor any extract from it may be reproduced, stored or transmitted in any form for any other purpose without prior written permission from EAC.

Requests for permission to reproduce this document for the purpose of selling it should be addressed as shown below or to EAC's member body in the country of the requester:

© East African Community 2019 — All rights reserved
East African Community
P.O. Box 1096,
Arusha
Tanzania
Tel: + 255 27 2162100
Fax: + 255 27 2162190
E-mail: eac@eachq.org
Web: www.eac-quality.net

Reproduction for sales purposes may be subject to royalty payments or a licensing agreement. Violators may be prosecuted.

Foreword

Development of the East African Standards has been necessitated by the need for harmonizing requirements governing quality of products and services in the East African Community. It is envisaged that through harmonized standardization, trade barriers that are encountered when goods and services are exchanged within the Community will be removed.

The Community has established an East African Standards Committee (EASC) mandated to develop and issue East African Standards (EAS). The Committee is composed of representatives of the National Standards Bodies in Partner States, together with the representatives from the public and private sector organizations in the community.

East African Standards are developed through Technical Committees that are representative of key stakeholders including government, academia, consumer groups, private sector and other interested parties. Draft East African Standards are circulated to stakeholders through the National Standards Bodies in the Partner States. The comments received are discussed and incorporated before finalization of standards, in accordance with the Principles and procedures for development of East African Standards. XXXXXX.

East African Standards are subject to review, to keep pace with technological advances. Users of the East African Standards are therefore expected to ensure that they always have the latest versions of the standards they are implementing.

The committee responsible for this document is Technical Committee EASC/TC 071, *Cosmetics and related products*

Contents

Page

Foreword.....	iii
1 Scope	1
2 Normative references	1
3 Terms and definitions	1
4 Requirements.....	1
4.1 General requirements.....	1
4.2 Specific requirements	2
4.3 Heavy metals requirements	2
5 Containers	2
6 Packaging	3
7 Labelling	3
8 Sampling.....	4
Annex A (normative) Determination of delivery rate of dispenser.....	5
A.1 Material and apparatus.....	5
A.1.5 Water bath	5
A.2 Procedure	5
A.3 Calculation.....	5
Annex B (normative) Determination of propellant composition.....	6
B.1 Procedure	6
B.2 Results	7
Annex D (normative) Spray test	9
Procedure	9
Annex E (normative) Determination of valve leakage.....	10
Annex F (Normative) Testing of filled aerosol containers.....	11
F.1 Procedure	11
F.2 Interpretation of results	11
Annex G (Normative) Stability of smell	12
G.1 Apparatus	12
G.2 Procedure	12
G.3 Results	12
Annex H (normative) Flame propagation	13
H.1 Principle.....	13
H.2 Apparatus	13
H.3 Procedure	14
Annex I (normative) Aerosol containers.....	15
J.1 Material	15
J.2 Construction.....	15
J.2.1 General.....	15
J.2.2 Soldered side seam containers.....	15
J.3 Internal finish	15
J.4 Filling volume.....	15
Annex J (normative) Determination of cloud temperature	16
J.1 Procedure	16
J.2 Results	16

Bibliography..... 17

DRAFT EAST AFRICAN STANDARD

Introduction

Air fresheners are consumer products used in homes, or commercial products used in restrooms, that typically emit fragrance.

Various air fresheners are packed in aerosol form. Every aerosol consists of a gas-tight container, a valve closure, an actuator button and a protective cap. Some dispensers have dip tubes. The operation of an aerosol is based on the discharge of its contents by the pressure of a compressed gas or the vapour phase generated by a propellant present in the container as a liquid. The container may be constructed of glass, plastic, or metals like tinfoil and aluminium.

DRAFT EAST AFRICAN STANDARD

Air freshener aerosols — Specification

1 Scope

This Draft East African Standard specifies the requirements, method of test and sampling for air fresheners in aerosol form.

This Standard does not apply to products for which therapeutic claims are made.

2 Normative references

The following documents are referred to in the text in such a way that some or all of their content constitutes requirements of this document. For dated references, only the edition cited applies. For undated references, the latest edition of the referenced document (including any amendments) applies.

EAS 377 (all parts), *Cosmetics and cosmetic products*

ISO 22716, *Cosmetics — Good Manufacturing Practices (GMP) — Guidelines on Good Manufacturing Practices*

ISO 7010, *Graphical symbols -- Safety colours and safety signs -- Registered safety signs*

ISO 24153, *Random sampling and randomization procedures*

3 Terms and definitions

No terms and definitions are listed in this document. ISO and IEC maintain terminological databases for use in standardization at the following addresses: — ISO Online browsing platform: available at <http://www.iso.org/obp>

4 Requirements.

4.1 General requirements.

4.1.1 All ingredients used including dyes, pigment and colours shall conform to all parts of EAS 377

4.1.2 The product shall contain acceptable amount of the ingredients necessary to effect the intended end use performance as stipulated on the label.

4.1.3 The manufacture shall certify that all the ingredients used such as mineral oils, extracts from natural herbs, dyes, perfumes etc. shall not be harmful or irritating to the skin or the sculp (where applicable).

4.1.4 The product shall not stain fabrics and general household furnishings.

4.1.5 The propellants used shall be hydrocarbons or any other propellants with low mammalian toxicity. Chloro-fluorocarbons (CFCs) banned under the Montreal Protocol for being ozone depleting substances shall not be used as aerosol propellants.

4.1.6 The flammability of an aerosol formulation shall be kept as low as possible to ensure safety during use.

4.1.7 The product shall not have any objectionable odour.

4.1.8 The product shall be produced, prepared and handled in accordance with ISO 22716.

4.2 Specific requirements

The product shall also comply with the requirements given in Table 1 when tested in accordance with the method prescribed therein.

Table 1 — Specific requirements for air freshener aerosols

Characteristic	Requirement	Method of test
Delivery rate g/s, min,	0.01	Annex A
CFCs	Absent	Annex B
Net weight delivery m/m, %, min.	95	Annex C
Spray test	To pass test	Annex D
Valve leakage, g/year, max.	5	Annex E
General leakage	To pass test	Annex F
Stability of smell	To pass test	Annex G
Non-volatile matter, % m/m, min.	10.0	Annex H
Cloud point	To pass test	Annex J
pH	3.0 – 8.5	EAS 847-17

4.3 Heavy metals requirements

The product shall comply with the heavy metal requirements given in Table 2 when tested in accordance with the test methods specified therein

Table 2 — Heavy metal requirements for air freshener aerosols

Heavy metal	Limit mg/kg, max	Test method
i) Lead (Pb)	10.0	EAS 847-16
ii) Arsenic (As)	2.0	
iii) Mercury (Hg)	2.0	
Note- The total amount of heavy metals as lead, mercury and arsenic, in combination in the finished product shall not exceed 10 mg/kg		

5 Containers

5.1 All filled aerosol containers shall be appropriately classified in terms of the flame propagation characteristics of their contents when determined in the manner described in Annex H.

- a) Highly flammable – If the average length of the flame is greater than 450 mm, or if the flame burns back to the actuator, or continues to burn when the test flame is extinguished.
- b) Flammable – If the average length of the flame is between 200 and 450 mm.
- c) Non-flammable – If the product does not flame or burn in the manner described above

5.2 The aerosol containers shall comply with the requirements of annex J with respect to internal pressure, materials of construction, filling volume, and performance

6 Packaging

The container shall be designed and manufactured to contain the product safely under normal conditions of distribution, storage and use.

7 Labelling

7.1 The package shall be legibly and indelibly marked with the following information:

- a) manufacturer's name and address;
- b) name of the product;
- c) date of manufacture;
- d) expiry date;
- e) net content;
- f) directions for use;
- g) flammability class (word or symbol);
- h) batch or code number;
- i) country of origin;
- j) The declaration 'Contains no CFC's or ODS';
- k) All ingredients shall be declared in descending order of predominance.

The INCI label names shall be used.

CFC – Chlorofluorocarbons

ODS – Ozone-depleting substances

INCI – International Nomenclature for Cosmetic Ingredients.

7.2 The following warnings shall be legibly and indelibly marked on the container:

- I. This container is pressurized'.
- II. Keep away from heat, naked flames and direct sunlight'.
- III. Do not puncture or incinerate even when empty'.

IV. Keep away from children’.

Any pictorial symbol(s) on the container shall be in accordance with ISO 7010.

8 Sampling

Representative samples shall be drawn for test from the market or anywhere else following in accordance with outlined ISO 24153. The samples shall be declared as conforming to the specification if they satisfy all the specified requirements.

DRAFT EAST AFRICAN STANDARD

Annex A (normative)

Determination of delivery rate of dispenser

A.1 Material and apparatus

A.1.1 Any suitable timing device

A.1.2 Balance having an accuracy to 0.01 g and with a capacity greater than 500 g

A.1.3 Pair of gloves made of cloth or fabric or towel for handling dispensers during test

A.1.4 Pair of tongs for removing dispensers from water bath

A.1.5 Water bath set at 26 °C ± 0.3 °C, thermostatically controlled

A.2 Procedure

A.2.1 Hold a dispenser upright, spray for two seconds to fill the education tube. Then weigh the dispenser

A.2.2 Submerge the dispenser into the water bath for 15 min using tongs, remove the dispenser from the bath and immediately dry the container with a towel. Spray the dispenser in one continuous burst for 10 s. Re-weigh the dispenser.

A.2.3 Repeat the procedure and take an average of three tests. The difference between the maximum and minimum delivery rates shall not exceed 0.2 g/s.

A.3 Calculation

The delivery rate, expressed in grams per second, shall be calculated as follows:

$$\text{Delivery rate} = \frac{M_1 - M_2}{N}$$

where

M_1 is the initial weight, in grams, of the dispenser;

M_2 is the final weight, in grams, of the dispenser; and

N is the time in seconds.

Annex B (normative)

Determination of propellant composition

B.1 Procedure

B.1.1 The analysis of the propellant mixture in most aerosol is carried out conveniently by gas chromatography. For sampling, a hypodermic needle is fitted to the valve of the aerosol can and approximately 0.5 g of the propellant is injected into the heavy duty centrifuge tube closed with a serum cap, containing about 8 ml of benzene. After mixing, 5- μ l samples are taken out from this tube with a microlitre syringe and injected into the gas chromatograph.

B.1.2 Two 4 572 mm \times 6.35 mm OD columns operated at 40 °C are recommended for the analysis containing 20 % weight hexadecane and diethylhexyl sebacate respectively on silanized chromosorb W60/S0 mesh.

The first column should be used mainly for initial screening and the second column for the confirmation and determination of the identified propellants.

Table B.1 lists the relative retention data of the most widely used propellant together with some other fluorinate hydrocarbons and benzene used as the solvent in the two columns.

Table B.1 — Relative retention data of propellants

Chemical name	Stationary phase diethylhexyl sebacate	Stationary phase hexadecane
Octafluorocyclobutane	0.214	0.122
1-chloro-1,2,2-trifluoroethylene	0.268	0.196
Propane	0.275	0.22
1,2-difluoroethane	0.289	0.141
Dichlorodifluoromethane	0.296	0.220
1,2-dichloro-1,1,2,2-tetrafluoromethane	0.345	0.290
Isobutane	0.366	0.378
Monochlorodifluoromethane	0.368	0.152
1-chloro-1,1-difluoroethane	0.402	0.236
n- butane	0.449	0.527
Vinylchloride	0.529	0.353
Trichlorofluoroethane	1.000	1.000
1,1,2-trichloro-1,2,2-tetrafluoroethane	1.254	1.342
Dichloromonofluoroethane	1.354	0.515
1,2-dibromo-1,1,2,2-tetrafluoroethane	1.634	1.363
Methylene chloride	2.565	1.070
Benzene	6.786	5.661

B.2 Results

The sample shall be considered as having failed the test if it contains any of the CFCs in Table D.1.

DRAFT EAST AFRICAN STANDARD

Annex C (normative)

Net weight delivery

C.1 For the determination of the net weight delivery, a random sample of at least three packages is selected. After the removal of any dust cover or caps not required for dispensing the product, the gross weight of each package is determined and after shaking for 15 s, the content of the lightest container is drained by holding the valve wide open. The exhausted container is weighed. The result is called wet-tare weight and is equal to the weight of the container plus any product remaining after draining.

C.2 Consequently, the regeneration allowance is determined and subtracted from the wet-tare weight to obtain the corrected wet-tare weight. The regeneration allowance is defined as the difference between the weight of the product which would be delivered through normal usage and the weight of the product delivered by the present accelerated procedure. It is calculated by multiplying the label weight of the container by 0.02 g and rounding the result to the next lowest gram.

C.3 By subtracting the corrected tare weight from the gross weight, the adjusted net weight of the package is obtained. If this is greater than 95 % of the label weight the lot is assumed to be satisfactory. However, if it is less than 95 % of the label weight, the lot is rejected

Annex D (normative)

Spray test

Procedure

Hand-shake the sample container for 15 sec. Spray for 10 seconds. The sample shall be deemed to have passed the test if defects such as “streamers” (solid or nearly solid stream) “droppers” (dripping valve) or no spraying are absent.

Annex E (normative)

Determination of valve leakage

Select 3 aerosol containers, and record the date and time to the nearest half-hour. Weigh each container to the nearest mg, and record the weight in mg of each, as W_1 . Place the containers in an upright position and retain at room temperature for not less than 3 days. Weigh each container again, recording the weight in mg of each, as W_2 and recording the date and time to the nearest half hour. Determine the time, T , in hours, during which the containers were under test.

Calculate the leakage rate, in mg per year, of each container taken using the formula:

$$(365) (24/T) (W_1 - W_2)$$

Where plastic-coated glass aerosol containers are tested, dry the containers in a desiccator for 18 hours, and set upright in a constant-humidity environment for 24 hours prior to determining the initial weight as indicated above. Perform the test under the same humidity conditions. Empty the contents of each container tested by utilizing any safe technique (e.g. chill to reduce pressure). Empty the residual contents by first rinsing with suitable solvents, then with a few portions of methanol. Retain the container, the valve and all associated parts as a unit, heat as W_3 and determine the net fill weight ($W_1 - W_3$) for each container tested.

If the average net fill weight has been determined previously, this value may be used as the net fill weight.

Annex F (Normative)

Testing of filled aerosol containers

F.1 Procedure

F.1.1 All filled aerosol containers shall be tested by immersion in a water bath set at 55 °C.

F.1.2 The container shall be such that the pressure generated within the immersed container reaches not less than 90 % of the pressure generated within the containers at equilibrium at 55 °C.

F.2 Interpretation of results

Any filled aerosol container that shall leak, get distorted or burst as a result of this test shall be considered to have failed the test and shall be discarded.

Annex G (Normative)

Stability of smell

G.1 Apparatus

G.1.1 Porcelain cup

G.1.2 Pincers

G.1.3 Bleached gauze, 10 pieces, of dimension 5 cm x 10 cm

G.1.4 Thermometer

G.1.5 Hygrometer

G.2 Procedure

Put some pieces of bleached gauze which have been pre-washed in hot water without soap and dried into a porcelain cup. Spray continuously about 2 ml of the sample into this cup. After the gauze gets soaked, remove one piece using a pair of pincers. Without squeezing it, dry it in an environment with temperature of $27\text{ }^{\circ}\text{C} \pm 2\text{ }^{\circ}\text{C}$ and humidity of $65\% \pm 5\%$ for 12 h.

G.3 Results

The product shall be taken to have passed the test if after 12 h, the smell of the sample can clearly be picked up.

Annex H (normative)

Flame propagation

H.1 Principle

The filled aerosol container is sprayed as a test flame under controlled conditions and the length of the burning spray cone is measured.

H.2 Apparatus

H.2.1 In its simplest form, the apparatus consists of a base marked at 0.15 m intervals, an adjustable stand to carry the aerosol container which may be raised or lowered to accommodate differences in container height, a means of measuring the burning spray cone (usually a one metre fuel placed horizontally at the same level as the top third of the flame, the hottest part) a means of igniting the spray cone in the form of a test flame 0.05 m \pm 0.005 m in height (usually a candle flame is used) as shown in Figure H.1

H.2.2 Water bath maintained at 20 °C. This equipment shall be used to bring the aerosol container and its contents to equilibrium at 20 °C (heat the cans to 20 °C in the water bath)

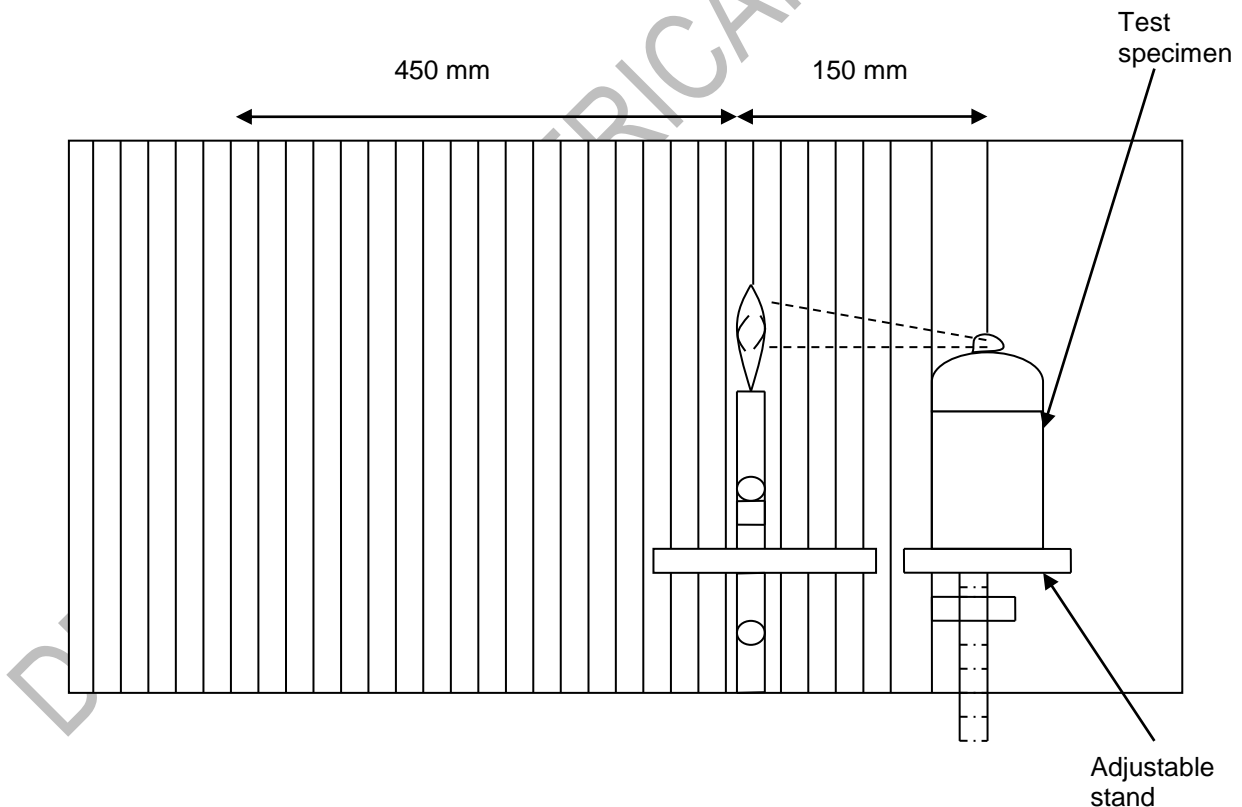

Figure H.1 — Apparatus for flame propagation test

H.3 Procedure

H.3.1 Place the aerosol container on the stand. Depress the actuator and adjust the height of the stand so that the spray cone will pass through the upper third test flame (hottest part).

H.3.2 Bring the aerosol container and its content to the equilibrium temperature of 20 °C. Place the container on the stand so that the point where the spray emerges is 0.15 m from the test flame. Then light the test flame and depress the actuator for 15 s to 20 s. Record the total length of the burning spray cone and specify whether or not it burns back to the actuator.

H.3.3 Extinguish the test flame and record whether the spray cone continues to burn while the actuator is depressed.

H.3.4 Repeat each test twice and record the flame length as the average of the three tests.

DRAFT EAST AFRICAN STANDARD

Annex I (normative)

Aerosol containers

J.1 Material

The container shall be made from any metal of uniform quality which can be shown to be suitable for the purpose. The aerosol dispenser shall be compatible with the intended contents and may be internally coated or otherwise surface treated with appropriate lacquers or chemical treatments to ensure compatibility.

J.2 Construction

J.2.1 General

The construction of the container shall be either seamless or with seams welded, soldered, brazed, double seamed or swaged.

J.2.2 Soldered side seam containers

J.2.2.1 Soldered side seams shall not be used for group 2 containers where the pressure of the contents at 55 °C is greater than $8.3 \times 10^5 \text{ N/m}^2$.

J.2.2.2 If the pressure developed by the contents of the container is greater than $6.9 \times 10^5 \text{ N/m}^2$ at 38 °C soldered side seams shall not be used for any container unless type tests have shown it to be satisfactory for the service intended.

J.3 Internal finish

The aerosol dispenser may be internally coated or otherwise surface treated with appropriate lacquers or by chemical treatments. Internal treatments shall be compatible with the intended contents.

J.4 Filling volume

J.4.1 The total liquid (together with any solid) contents at a temperature of 55 °C shall occupy not more than 90 % of the internal volume of the closed dispenser.

J.4.2 For containers having a concave end with a radius of curvature less than the diameter of the body and where the end reverses before the container bursts when tested in accordance with clause 6, the total liquid (together with any solid) contents at a temperature of 55 °C shall occupy not more than 95 % of the closed dispenser.

J.5 Performance requirements

All filled dispensers shall be tested in accordance with Annex F.

Annex J
(normative)

Determination of cloud temperature

J.1 Procedure

J.1.1 Pour 20 mL of cologne into a wide cylinder and close it with a plug. Insert a thermometer having scale up to $-20\text{ }^{\circ}\text{C}$. Immerse the thermometer into the liquid in such a manner that its bulb is situated at the same distance from the bottom and walls.

J.1.2 Immerse the cylinder containing the liquid into a cooling mixture containing ice and salt. After cooling the sample to $5\text{ }^{\circ}\text{C}$, take out the cylinder, shake it and scan it in transmitted daylight, or in the light of a 40 w electric lamp.

J.2 Results

The product shall be taken to have passed the test if no turbidity appears at a temperature of $5\text{ }^{\circ}\text{C}$. The cologne should be transparent

Bibliography

- [1] KS 1669: 2001, *Specification for cosmetic and air freshener aerosols*
- [2] TZS 811: 2017, *Cosmetics and air freshener aerosols — Specification*

DRAFT EAST AFRICAN STANDARD

DRAFT EAST AFRICAN STANDARD